

Model DK-2 Drafting Kit Assembly for All Chair Models

Parts Listing

- (1) Circular Foot Rest
- (1) Screw Knob
- (1) 9" Extension Tube
- (1) 12" Extension Tube

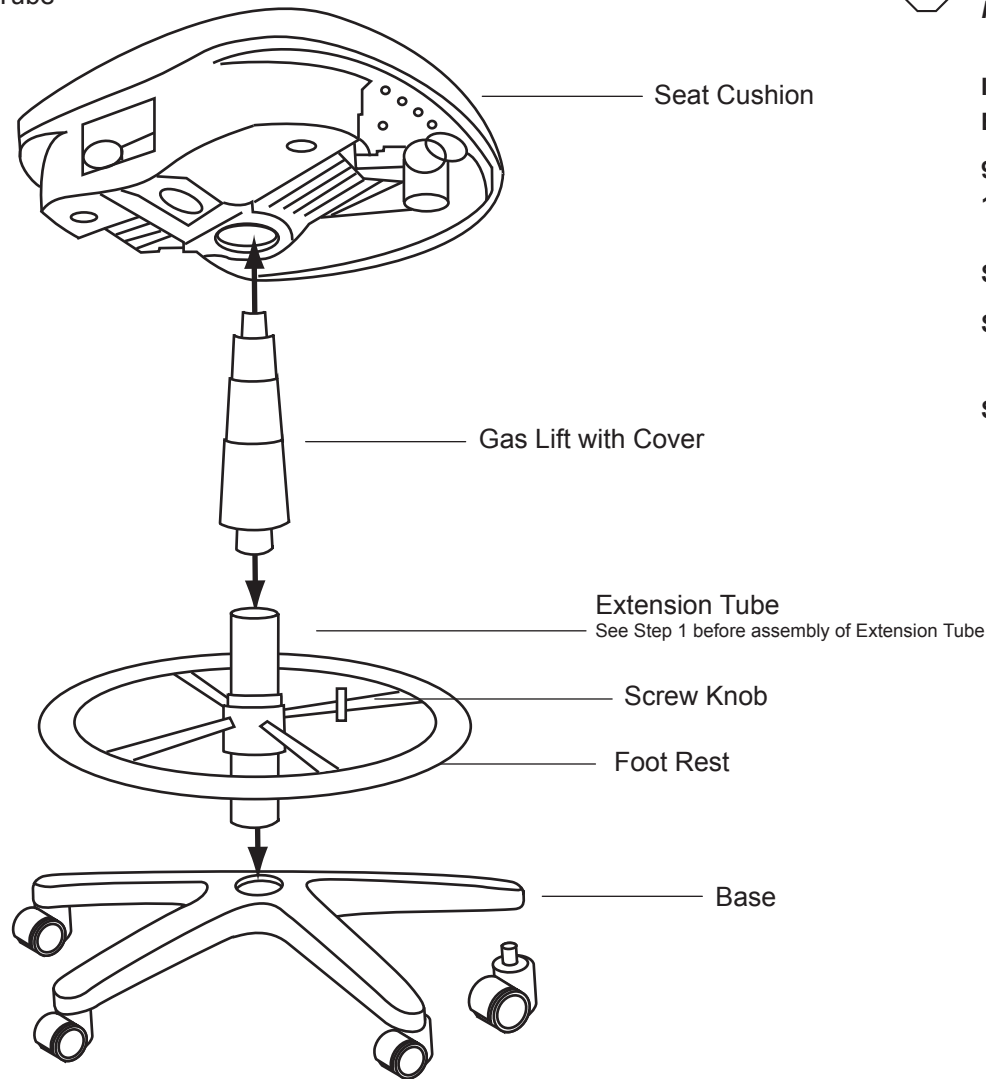

Assembly Instructions



Tools Needed: Phillips Head Screwdriver
Please read all instructions before assembly.

IMPORTANT: Prior to assembly, select only one Extension Tube size for desired height.

9" Extension Tube will adjust the seat height from 24" - 28"
12" Extension Tube will adjust the seat height from 27" - 31"

Step 1: Choose the desired Extension Tube to insert into the base.

Step 2: Slide the Foot Rest Ring over the smaller tapered end of Extension Tube and tighten the Screw Knob.

Step 3: Insert the bottom of the Gas Lift Cylinder into the Extension Tube opening. Then place the seat on top of the gas lift. One of the extension tubes will be left over after assembly is complete. You may save for future use or discard.

CAUTION:

1. Do not use this chair as a step ladder.
2. Check for loose screws and tighten them every 6 months.



Holly Springs, NC, USA
800-520-7471 (voice)
919-303-6389 (voice)
919-362-4765 (fax)
support@ofminc.com
www.ofminc.com